

CBM-9/7 4P VR 373W



Dimensiones y conexiones Dimensions and wiring

Características Characteristics

Tensión Voltage	Monofásica 230V 50Hz Single-phase 230V 50Hz
Tipo motor Motor type	1V IP20 cl.F 1S
Velocidad Speed	4 polos 4 poles
Potencia motor Motor power	373 W
Intensidad absorbida máxima Maximum absorbed current	3,6 A
Condensador Capacitor	15 nF/450V
Temperatura del aire Air temperature	-20°C < T < +40°C
Peso Weight	11,7 kg
Código ventilador Fan code number	5128970800 ----- (MP)
Código motor Motor code number	9073003500

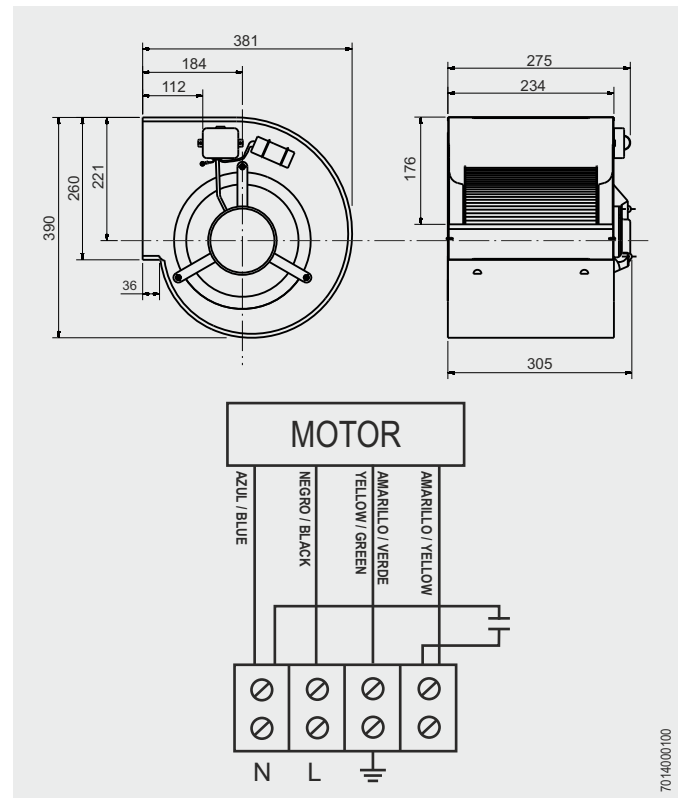

Curvas características / Performance curves (18/02/2010)

