

CBM-9/9 6P VR 122W



Dimensiones y conexiones Dimensions and wiring

Características Characteristics

Tensión Voltage	Monofásica 230V 50Hz Single-phase 230V 50Hz
Tipo motor Motor type	1V IP20 cl.F 1S
Velocidad Speed	6 polos 6 poles
Potencia motor Motor power	122 W
Intensidad absorbida máxima Maximum absorbed current	1,7 A
Condensador Capacitor	8 F/450V
Temperatura del aire Air temperature	-20°C < T < +40°C
Peso Weight	12,4 kg
Código ventilador Fan code number	5128973000 ----- (MP)
Código motor Motor code number	9073007300

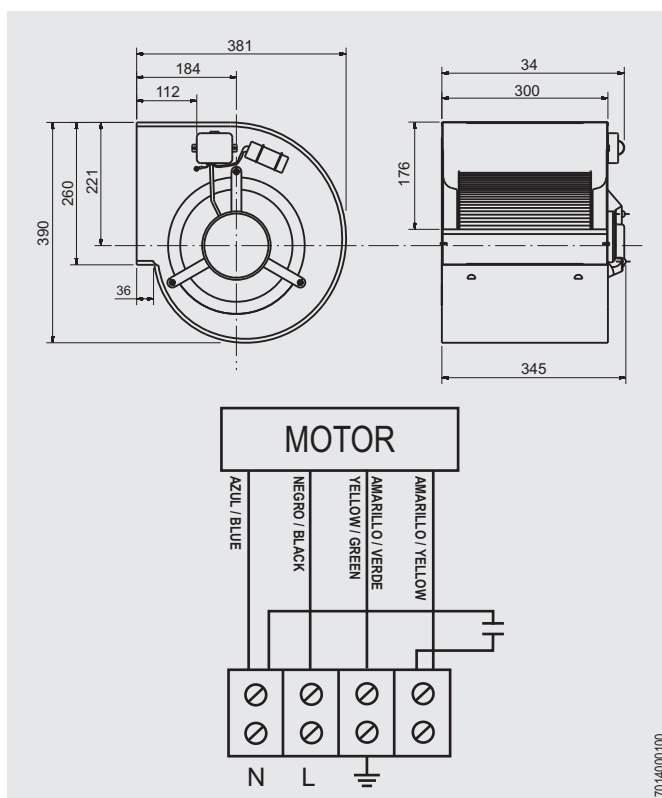

Curvas características / Performance curves (15/03/2013)

