

Nominal data

Type	S4D400-AP12-79				
Motor	M4D074-EI				
Phase		3~	3~	3~	3~
Nominal voltage	VAC	230	230	400	400
Connection		Δ	Δ	Y	Y
Frequency	Hz	50	60	50	60
Type of data definition		fa	fa	fa	fa
Valid for approval / standard		CE	CE	CE	CE
Speed	min ⁻¹	1450	1690	1450	1690
Power input	W	135	185	135	185
Current draw	A	0.76	0.68	0.44	0.39
Max. back pressure	Pa	150	120	150	120
Min. ambient temperature	°C	-25	-25	-25	-25
Max. ambient temperature	°C	40	40	40	40
Starting current	A	3.0	3.0	1.7	1.7

ml = Max. load · me = Max. efficiency · fa = Running at free air · cs = Customer specs · cu = Customer unit
Subject to alterations

Data according to ErP directive

Installation category	A
Efficiency category	Static
Variable speed drive	No
Specific ratio*	1.00

* Specific ratio = $1 + p_{fs} / 100\,000\text{ Pa}$

		Actual	Request 2015
Overall efficiency η_{es}	%	32.7	29.1
Efficiency grade N		43.6	40
Power input P_e	kW	0.19	
Air flow q_v	m ³ /h	2595	
Pressure increase p_{fs}	Pa	91	
Speed n	min ⁻¹	1415	

Data definition with optimum efficiency. LU-27622
The ErP data is determined using a motor-impeller combination in a standardised measurement configuration.

S4D400-AP12-79

AC axial fan

sickled blades (S series), single inlet
with guard grille for short nozzle

Technical features

Mass	5.9 kg
Size	400 mm
Surface of rotor	Coated in black
Material of blades	Sheet steel, coated in black
Material of guard grille	Steel, coated in black plastic (RAL9005)
Number of blades	5
Direction of air flow	"V"
Direction of rotation	Counter-clockwise, seen on rotor
Type of protection	IP 44; Depending on installation and position as per EN 60034-5
Insulation class	"B"
Humidity class	F2-2
Max. permissible ambient motor temp. (transp./ storage)	+ 80 °C
Min. permissible ambient motor temp. (transp./storage)	- 40 °C
Mounting position	Shaft horizontal or rotor on bottom; rotor on top on request
Condensate discharge holes	Rotor-side
Operation mode	S1
Motor bearing	Ball bearing
Touch current acc. IEC 60990 (measuring network Fig. 4, TN system)	< 0.75 mA
Cable exit	Variable
Protection class	I (if protective earth is connected by customer)
Product conforming to standard	EN 60335-1, motor does not have factory-installed overheating protection
Approval	UL 1004-1; CSA C22.2 Nr.100

S4D400-AP12-79

AC axial fan

sickled blades (S series), single inlet
with guard grille for short nozzle

Product drawing

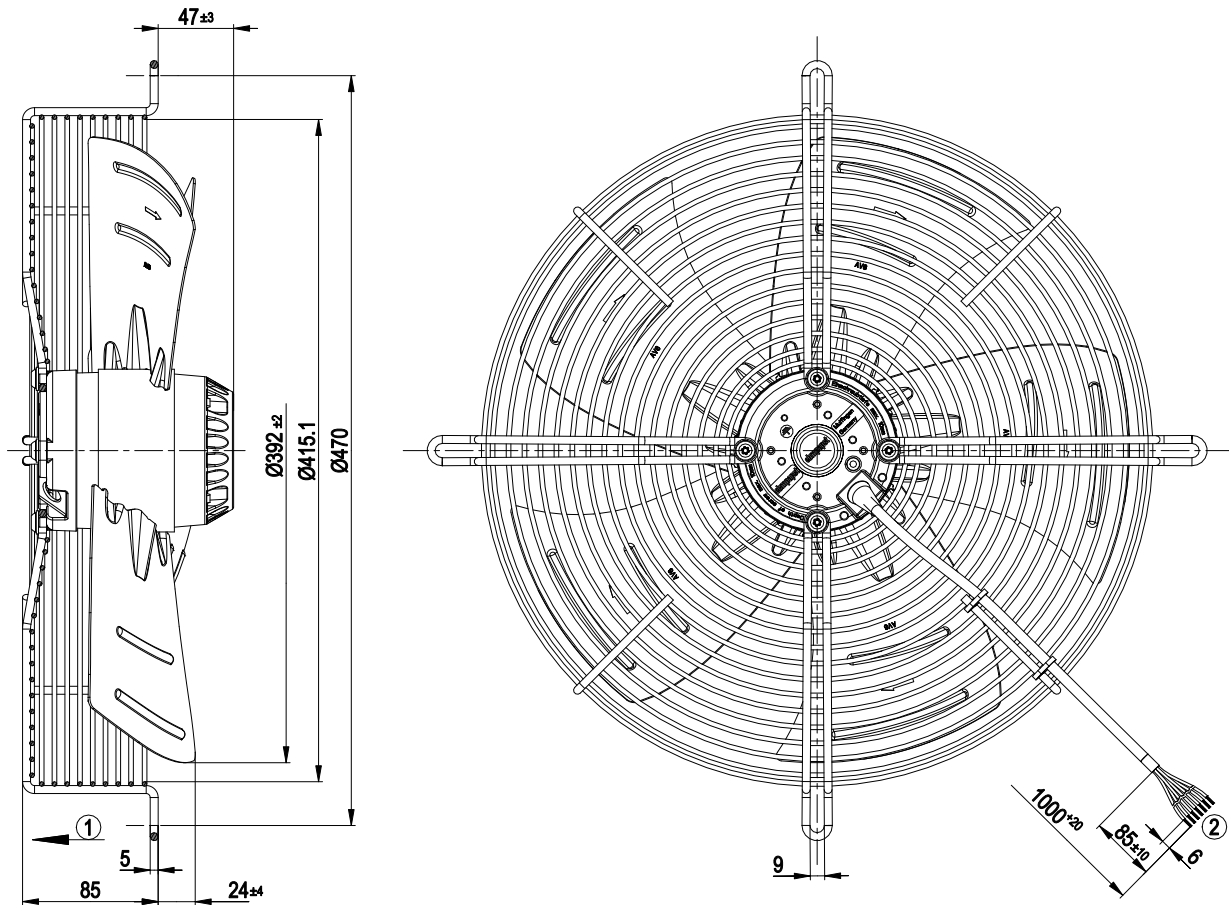

- | | |
|---|---|
| 1 | Direction of air flow "V" |
| 2 | Connection line PVC 7G 0.5 mm ² , 7x lead tips crimped |

AC axial fan

sickled blades (S series), single inlet
with guard grille for short nozzle

Connection screen

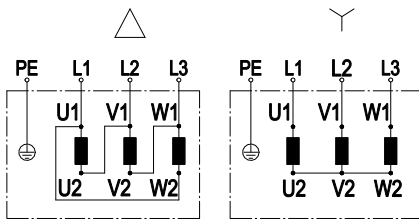

Change direction of rotation by reversing two phases

	Three-phase motor	Δ	Delta connection	Y	Star connection
L1	= U1 = black	L2	= V1 = blue	L3	= W1 = brown
U2	green	V2	white	W2	yellow
PE	green/yellow				

AC axial fan

sickled blades (S series), single inlet
with guard grille for short nozzle

Charts: Air flow 50 Hz

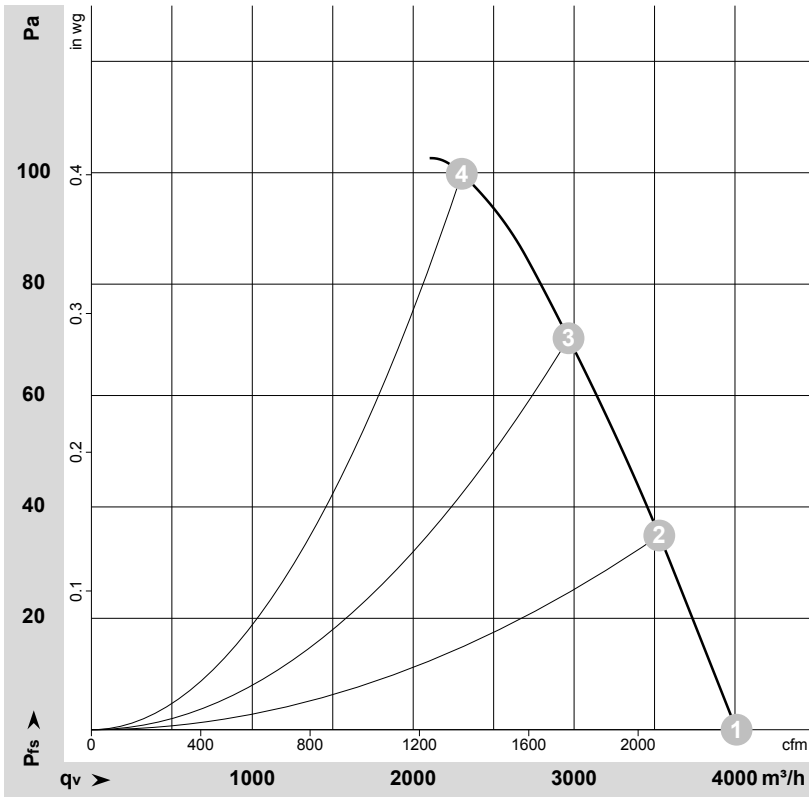

$\rho = 1,15 \text{ kg/m}^3 \pm 2\%$

Measurement: LU-27622

Air performance measured as per ISO 5801 Installation category A. For detailed information on the measuring set-up, please contact ebm-papst. Suction-side noise levels: LwA measured as per ISO 13347 / LpA measured with 1m distance to fan axis. The values given are valid under the measuring conditions mentioned above and may vary according to the actual installation situation. With any deviation from the standard set-up, the specific values have to be checked and reviewed with the unit installed.

Measured values

	Conn.	U	f	n	P _e	I	qv	p _{fs}
		V	Hz	min ⁻¹	W	A	m ³ /h	Pa
1	Y	400	50	1450	135	0.44	4010	0
2	Y	400	50	1435	161	0.47	3530	35
3	Y	400	50	1420	183	0.49	2965	70
4	Y	400	50	1410	204	0.50	2300	100

Conn. = Connection · U = Supply voltage · f = Frequency · n = Speed · P_e = Power input · I = Current draw · qv = Air flow · p_{fs} = Pressure increase

AC axial fan

sickled blades (S series), single inlet
with guard grille for short nozzle

Charts: Air flow 60 Hz

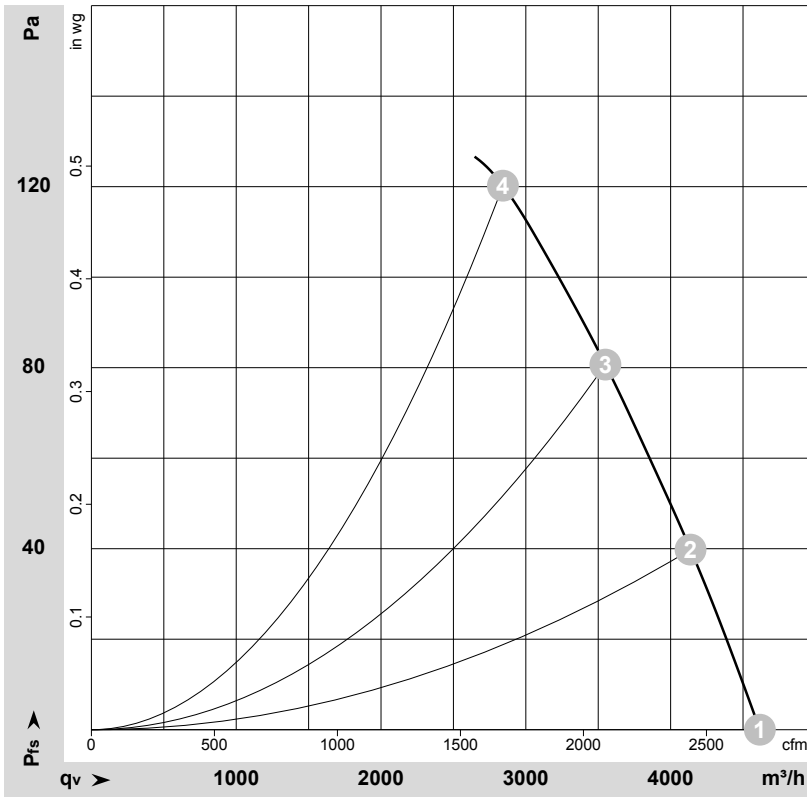

$\rho = 1,15 \text{ kg/m}^3 \pm 2\%$

Measurement: LU-27623

Air performance measured as per ISO 5801 Installation category A. For detailed information on the measuring set-up, please contact ebm-papst. Suction-side noise levels: LwA measured as per ISO 13347 / LpA measured with 1m distance to fan axis. The values given are valid under the measuring conditions mentioned above and may vary according to the actual installation situation. With any deviation from the standard set-up, the specific values have to be checked and reviewed with the unit installed.

Measured values

	Conn.	U	f	n	P _e	I	qv	p _{fs}
		V	Hz	min ⁻¹	W	A	m ³ /h	Pa
1	Y	400	60	1690	185	0.39	4615	0
2	Y	400	60	1660	223	0.45	4140	40
3	Y	400	60	1635	257	0.49	3550	80
4	Y	400	60	1605	292	0.54	2840	120

Conn. = Connection · U = Supply voltage · f = Frequency · n = Speed · P_e = Power input · I = Current draw · qv = Air flow · p_{fs} = Pressure increase